

Operating and Installation Instructions

ePush-Lock

Content

1. General Information	4
2. Safety	4
2.1. Intended use	4
2.2. Operating conditions	5
2.3. Basic safety instructions	5
2.3.1. Avoid electric shock	5
2.3.2. Avoid injuries	5
2.3.3. Avoid damage to device	5
2.4. Personnel qualifications	5
2.5. Personal protective equipment	6
3. Description	6
4. Design	7
5. Spacers	8
6. Emergency release	9
6.1. Delivery status for ePush-Lock versions 3000-U600-01, 3000-U600-02 and 3000-U600-05	9
6.2. Delivery status for ePushLock versions 3000-U600-03 and 3000-U600-04	10
6.3. Opening from the inside	12
7. Electrical data and connections	13
7.1. Power supply and output	13
7.2. Connection plug and cable assignment	13
7.3. Open Collector Outputs	13
8. Control and signal sequences	14
8.1. Version for push button control	14
8.2. Version for toggle switch	15
8.3. Version for central locking	16
9. Assembly	17
10. Data sheet	21

1. General Information

These instructions will help to securely install the ePush-Lock. In the following, the ePush-Lock is called "device".

These instructions are part of the device.

- Always keep these instructions with the device.
- Include these instructions when you sell the device or pass it on in any other way.

Manufacturer address

EMKA Beschlagteile GmbH & Co. KG
Langenberger Strasse 32

42551 Velbert, Germany

Phone: +49 2051/273 0

Fax: +49 2051/273 128

E-Mail: info@emka.de

Authorized representative for the documentation

Mr. Sebastian Geck

EMKA Beschlagteile GmbH & Co. KG
Langenberger Strasse 32

42551 Velbert, Germany

Phone: +49 202/7496 462

Fax: +49 202/7496 468

2. Safety

2.1. Intended use

The ePush-Lock has been designed for locking storage space flaps and doors on motorhomes, recreational vehicles and caravans. The use in other applications can only be approved on request by EMKA Beschlagteile GmbH & Co. KG. and requires a precise description of the intended use.

When using the ePush-Lock, a maximum distance of 800 mm between the individual locking points (fixing points) is recommended.

Each application must be validated and checked as a complete system by the manufacturer / distributor for satisfactory and sufficient safety and usability.

Use in vehicles requires active electronic locking. The vehicle may only start moving if this safe condition is ensured by the vehicle control system (for example, central locking system or ignition interruption) before driving off.

2.2. Operating conditions

Make sure that the device is only used under the following environmental conditions:

- Temperature: -20 °C to +60 °C
- Relative humidity: 15% to 85%, non-condensing

The device meets the requirements of protection class IP2x.

2.3. Basic safety instructions

2.3.1. Avoid electric shock

Electrical shock possible when connecting the device.

- Make sure that the device is only connected by qualified electricians.
- Make sure that the conditions at the installation location correspond to the protection class of the device. The protection class can be found in the technical data.
- Before connecting, ensure that all electrical power is switched off.
- Do not put any visibly damaged device into operation.

2.3.2. Avoid injuries

Avoid injury to eyes from drilling dust when drilling holes.

- Wear safety glasses.

2.3.3. Avoid damage to device

Avoid damage to the electrical connection cable due to kinks.

- Lay the connection cable to the device so that it is not kinked or squeezed.

Avoid damage to the device due to excessive torque when fastening.

- Tighten screws and nuts with max. 1.5 Nm

Avoid damage to the device due to moisture.

- Make sure that the conditions at the installation location correspond to the protection class of the device. The protection class can be found in the technical data.

2.4. Personnel qualifications

People who assemble or connect the device must have the following skills:

- Determine visible damage of the device before installation
- Fasten screws or nuts with specified torque
- Identify hazards that may occur when handling electrical equipment and avoid hazards
- Establish electrical connections in accordance with applicable regulations and guidelines (electrical specialist)

2.5. Personal protective equipment

- Wear suitable personal protective equipment when working with the device.
- When compiling personal protective equipment, observe and follow the regulations at the place of use.
- Wear safety glasses when drilling holes.
- Wear hearing protection when drilling holes.

3. Description

The concealed locking device ePush-Lock can keep a door mechanically closed and additionally lock it electronically. Open collector outputs are available for remote monitoring of door status (open/closed) and locking status (unlocked/locked). In case of a status change, the electrical signal changes between the voltage connected to the open collector via external resistor (typically the operating voltage Vcc for the lock) and GND.

To lock a door, it must be manually closed first. The output for "Door Status" will change from Vcc to GND. Then the signal to lock the door must be applied. A locking bolt in the ePush-Lock travels into the position "locked" and prevents the door from being opened. The output "Lock Status" changes from Vcc to GND.

To open the door again, the signal for to unlock must be applied. The locking bolt in the ePush-Lock travels back to position "unlocked". The output "Lock Status" changes back to Vcc. The door can then be opened manually again. The output "Door Status" changes back to Vcc.

If the signal to lock the door is given while the door is open, the locking bolt tries to travel into the "locked" position. Since this is not possible, it travels back to the position "unlocked".

4. Design

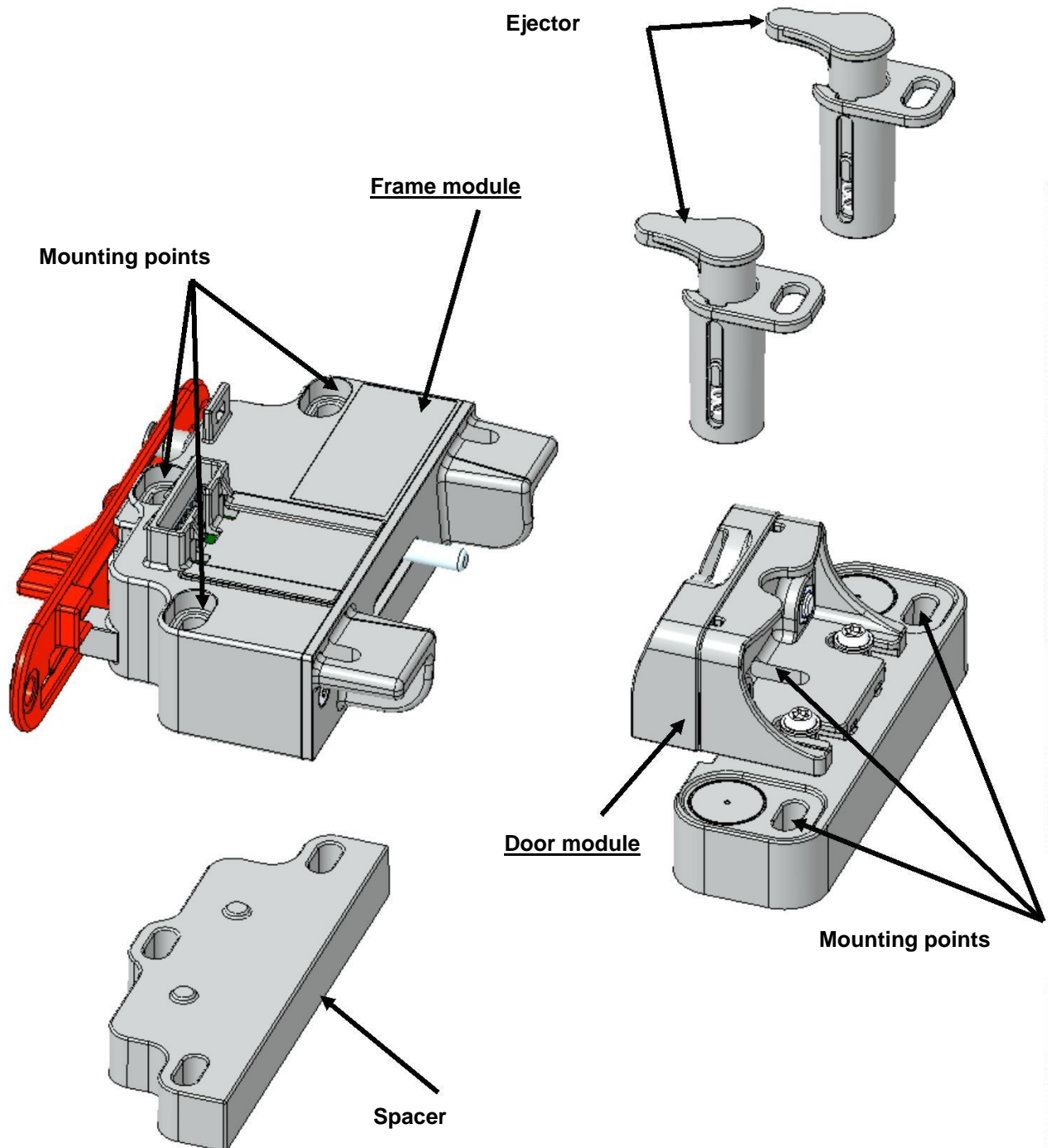

5. Spacers

Delivery status

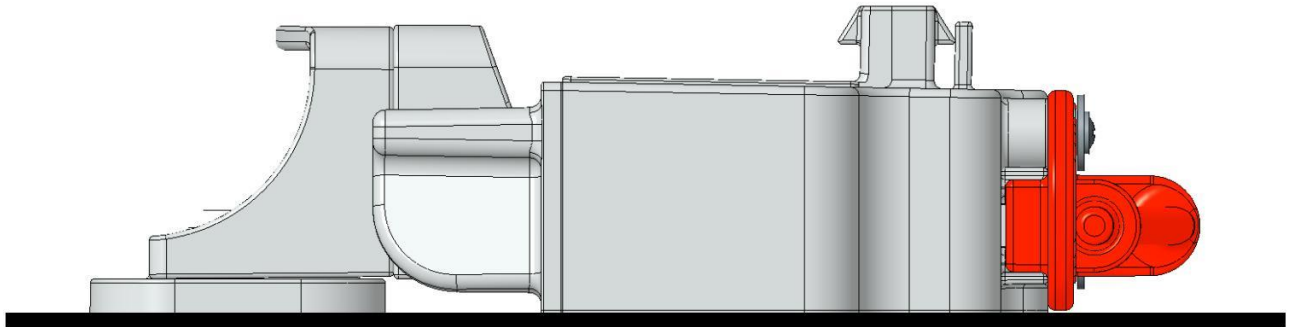

Optional

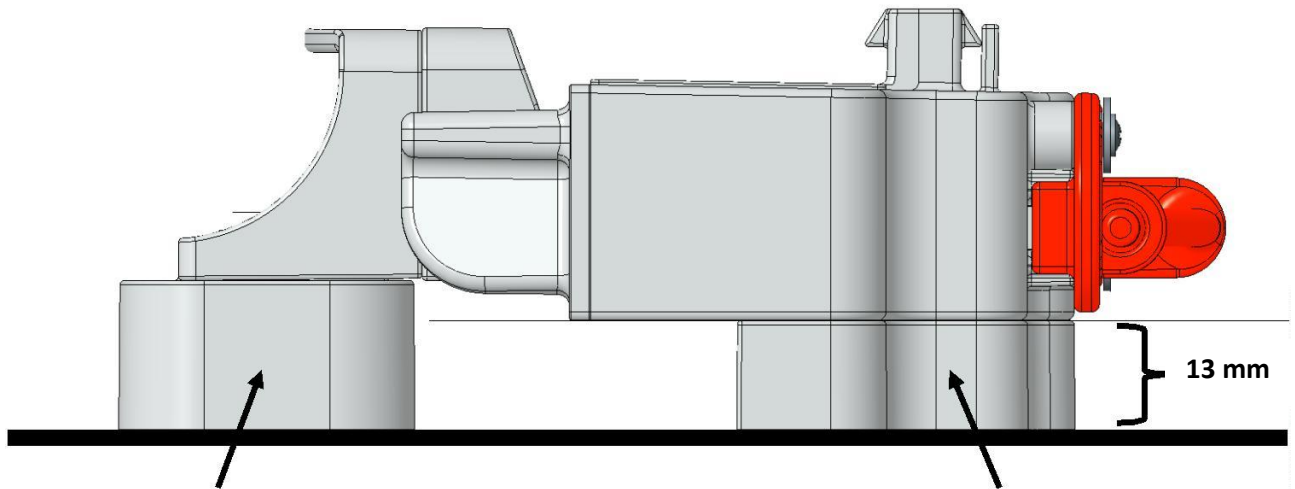

Optional:
Spacer
3000-112-25 for 13mm
Different height upon request

Optional:
Spacer
3000-112-11 for 13mm,
Different height upon request

6. Emergency release

6.1. Delivery status for ePush-Lock versions 3000-U600-01, 3000-U600-02 and 3000-U600-05

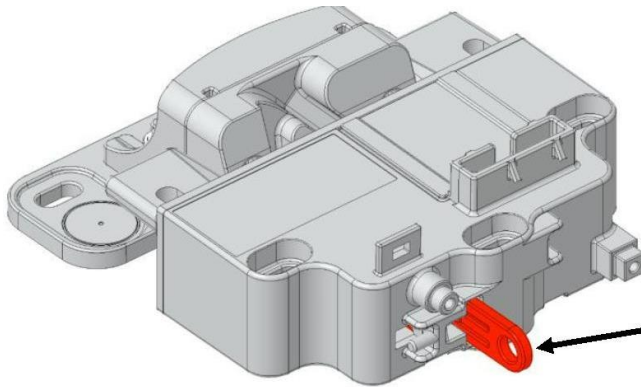

An emergency release is necessary if the door has been electrically locked and electrical unlocking is not possible.

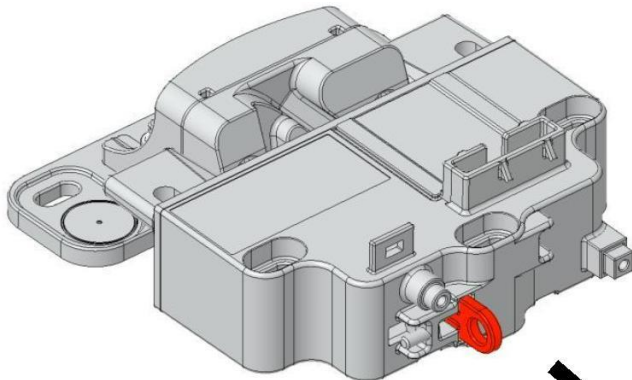

For emergency unlocking, the locking bolt is pulled in the direction of the arrow until it engages. This can be done manually or via Bowden cable.

A Ø 6mm eyelet is provided to connect a Bowden cable.

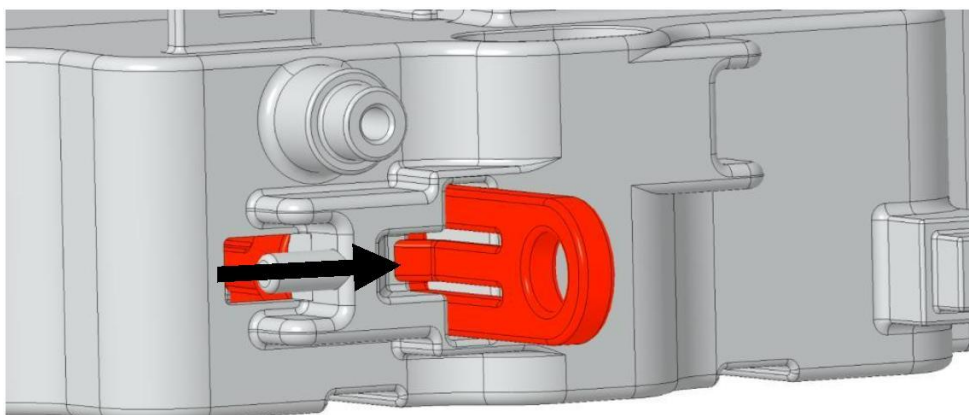

After opening the door, the clip must be pushed back, so that the locking bolt returns to its original position.

6.2. Delivery status for ePushLock versions 3000-U600-03 and 3000-U600-04

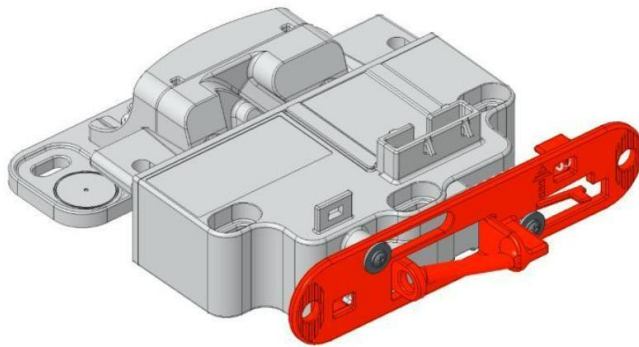

For emergency release, the red emergency opening slider is pulled in the direction of the arrow until it engages. This can be done manually or via a Bowden cable.

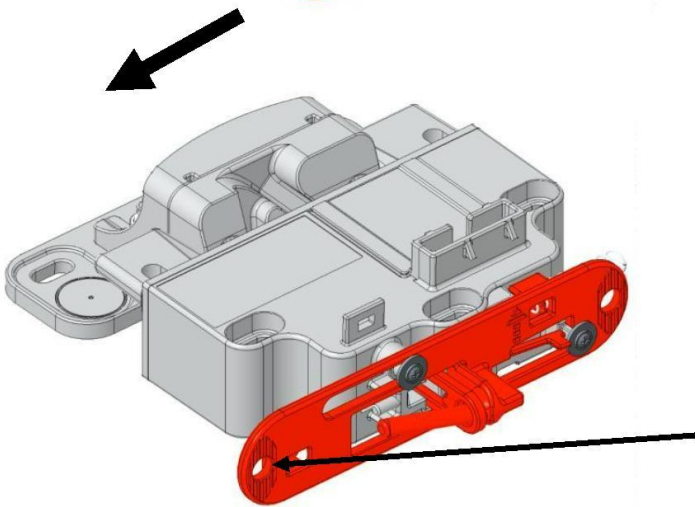

A Ø 6mm eyelet is provided to connect a Bowden cable.

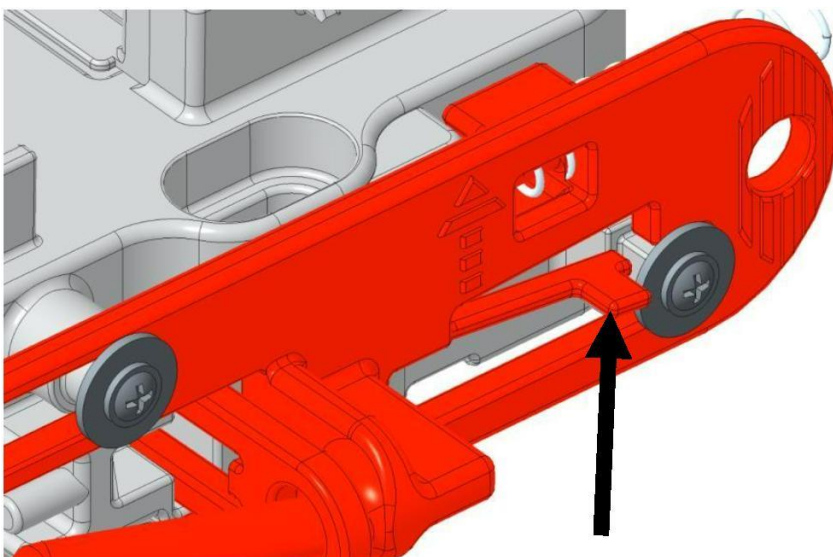

After opening the door, the clip must be pushed back. Then the emergency opening slider must be pushed back, so that the locking bolt can return to its original position.

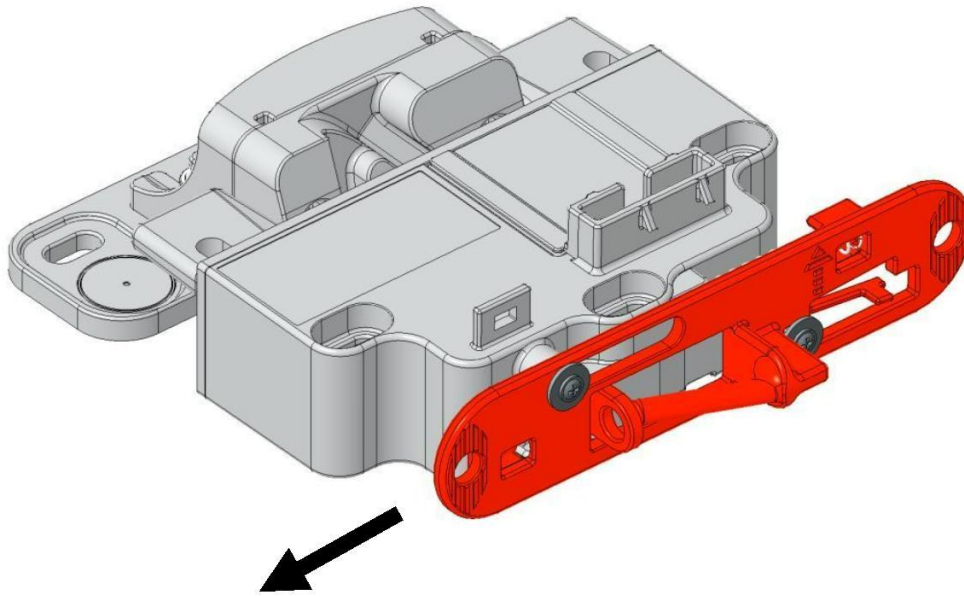

Pull direction
Standard

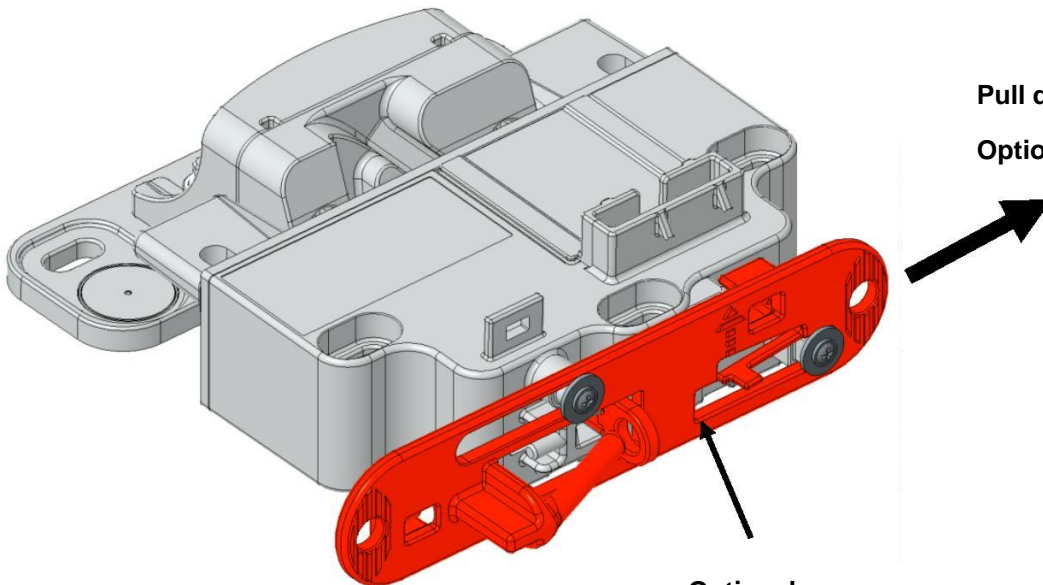

Pull direction
Optional

Optional:
Emergency opening slider
3000-112-18

6.3. Opening from the inside

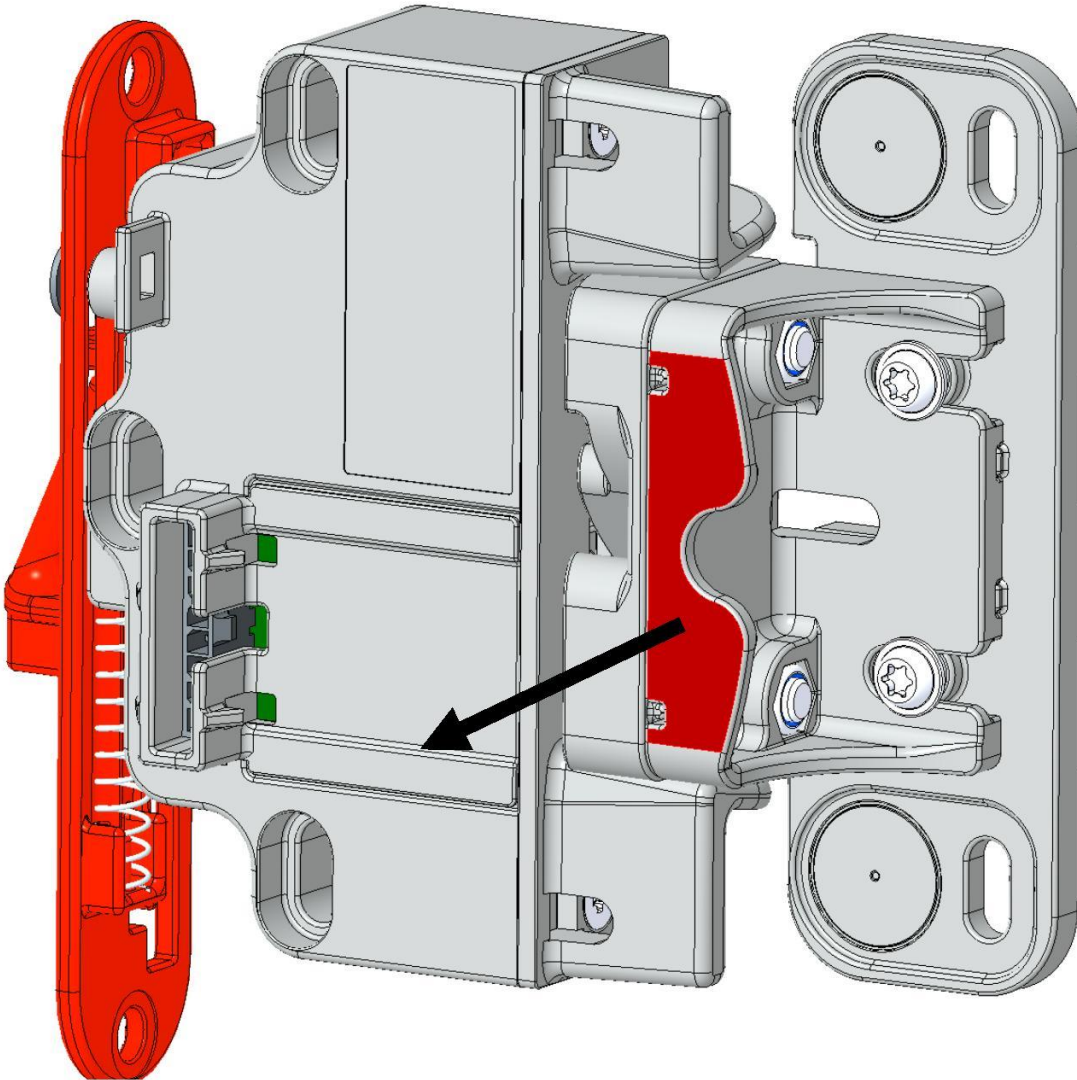

In the emergency or electrically unlocked state, pull in the marked area to open the door.

7. Electrical data and connections

7.1. Power supply and output

Supply voltage: 9 ... 32 VDC, 500 mA
Outputs: Open collector, max. 32 V, 50 mA

7.2. Connection plug and cable assignment

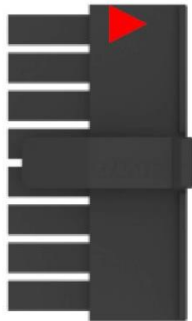

		Versions "push button", "toggle switch" and central locking with continuous current (same voltage level for locking and unlocking)	Version for central locking
#	Color	Function	Function
1	White	Input "Lock"	Input "Lock", Channel 1
2	Brown	Input "Unlock"	Input "Unlock", Channel 2
3	Yellow	-	-
4	Red	Vcc	-
5	Green	GND	GND
6	Grey	-	
7	Pink	Output "Lock Status"	Output "Lock Status"
8	Blue	Output "Door Status"	Output "Door Status"

The connection cable with the EMKA art.-no. 3000-11 can be used.

Alternatively, the following components are required on the ePush-Lock side for customized connecting cables:

- 1 x Connector type MATE-N-LOK (1445022-8)
- 8 x socket contact 1-795606-1

7.3. Open Collector Outputs

For the evaluation of the Open Collector Outputs, an external resistor R_{ext} 1k Ω ... 15k Ω according to the following circuit diagram must be connected.

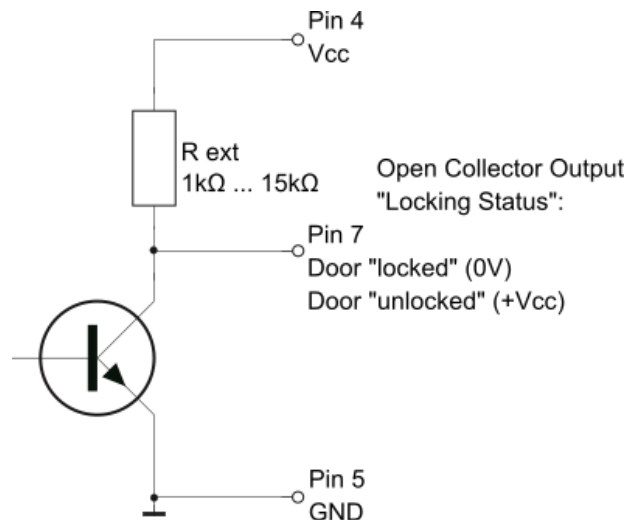
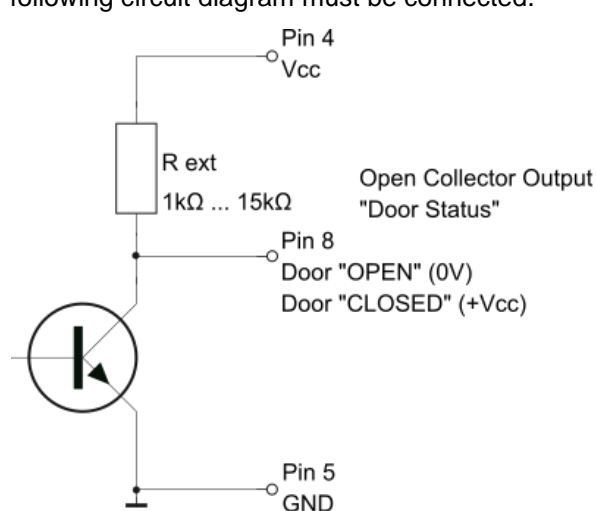

8. Control and signal sequences

8.1. Version for push button control

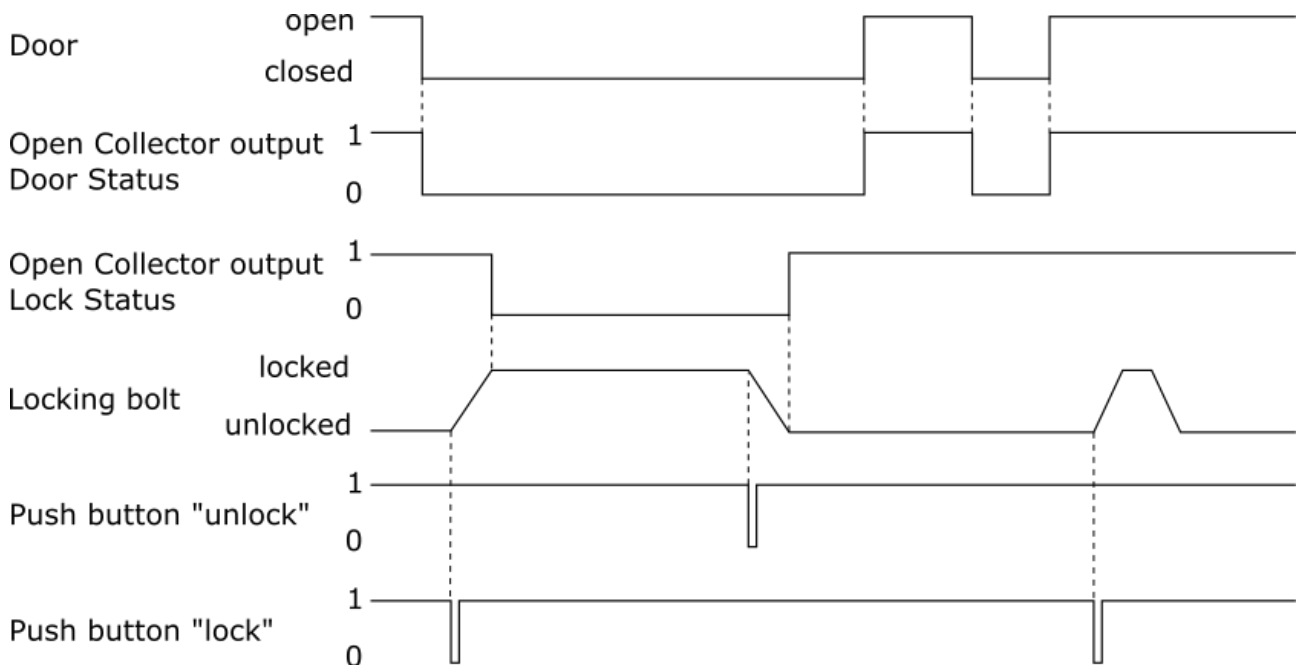

Initial state "Open door"

Open Collector Outputs "Status Door" and "Status Lock" are on Vcc level.

Door is closed manually

Open Collector Output "Status Door" changes to GND.

Locking the door

The "Lock" button must be pressed briefly. The locking bolt travels to the position "locked", the Open Collector output "Lock Status" changes to GND level. The door is securely locked.

Door locked

Open Collector Outputs "Status Door" and "Status Lock" are on GND level.

Unlock the door

The "Unlock" button must be pressed briefly. The locking bolt moves to the position "unlocked", the Open Collector Output "Status Lock" changes to Vcc. The door is still closed but unlocked.

Opening the door

By pressing on the door in the lock area, it can be opened. The Open Collector Output "Status Door" changes to Vcc.

Special case "Lock open door"

If the "Lock" button is pressed briefly while the door is open, the locking bolt tries to travel into the position "locked". Since this is not possible, it travels back to the position "unlocked".

Another special case arises in connection with the emergency release if the locking bolt is pulled when the door is locked. Then the locking bolt automatically moves to the unlocked position. The door can then be opened and closed as required.

8.2. Version for toggle switch

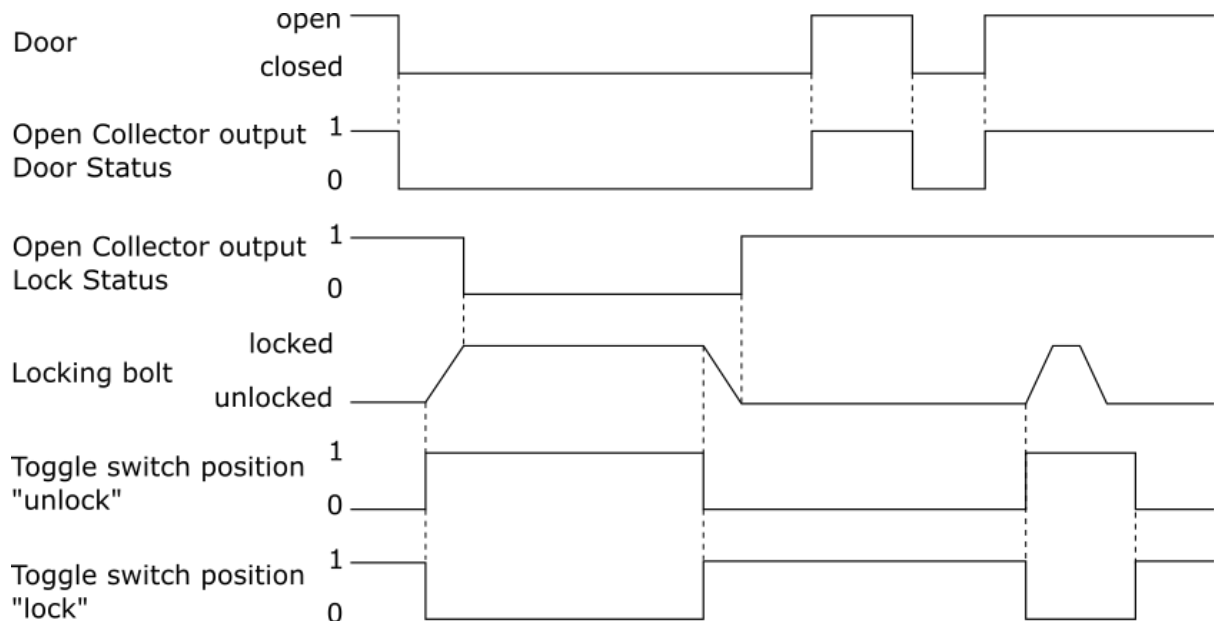

Initial state "Open door"

The Open Collector Outputs "Door Status" and "Lock Status" are on Vcc level. The toggle switch "Lock/Unlock" is in position "Unlock".

Door is closed manually

Open Collector Output "Door Status" changes to GND level.

Locking the door

The toggle switch must be switched from the "Unlock" to the "Lock" position. The locking bolt moves to the "locked" position, the Open Collector output "Lock Status" changes to GND. The door is securely locked.

Door locked

Die Open Collector Outputs " Door Status" and "Lock Status" are on GND level.

Unlocking the door

The toggle switch must be switched from position "Lock" to position "Unlock". The locking bolt moves to the "unlocked" position, the Open Collector Output "Lock Status" changes to Vcc. The door is still closed but unlocked.

Opening the door

By pressing on the door in the lock area, it can be opened. The Open Collector Output "Door Status" changes to Vcc.

Special case "Lock open door"

If the toggle switch is switched from position "Unlock" to "Lock" position while the door is open, the locking bolt first tries to travel into the "locked" position. Since this is not possible, it travels back to the position "unlocked". If the door is then closed again and shall also be locked, the switch must first be set to the "Unlock" position. After that, the door can be locked again as described above.

Another special case arises in connection with the emergency release. If the locking bolt is pulled while the door is locked, the locking bolt automatically travels to the unlocked position. The door can then be opened and closed as required.

8.3. Version for central locking

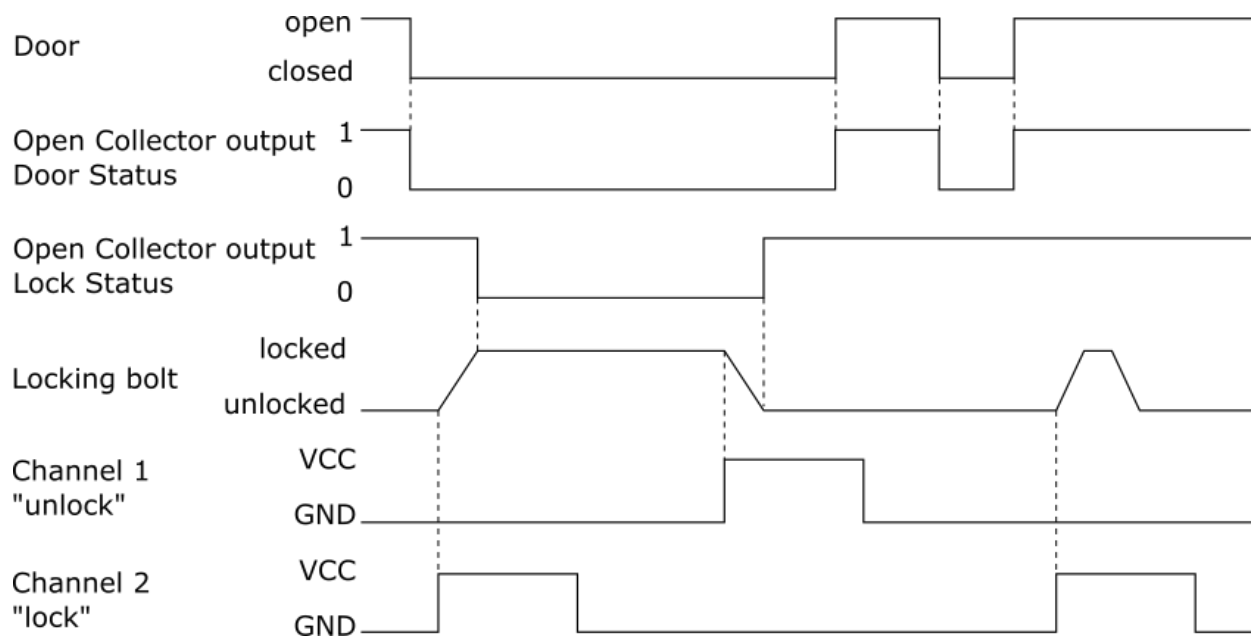

Initial state "Open door"

The Open Collector outputs "Door Status" and "Lock Status" are on Vcc level, the two control inputs channel 1 and channel 2 are on GND.

Door is closed manually

Open Collector Output "Door Status" changes to GND.

Locking the door

Control input channel 2 must be switched to Vcc for at least 5 seconds, then back to GND. The locking bolt travels to the position "locked", the Open Collector output "Lock Status" changes to GND. The door is securely locked.

Door locked

Open Collector Outputs "Door Status" and "Lock Status" are on GND.

Unlock the door

The control input channel 1 must be switched to Vcc for at least 5 seconds, then back to GND. The locking bolt moves to the position "unlocked", the Open Collector output "Lock Status" changes to Vcc. The door is still closed but unlocked.

Opening the door

By pressing on the door in the lock area, it can now be opened. The Open Collector output "Door Status" changes to Vcc.

Special case "lock open door"

If channel 2 is switched to Vcc when the door is open, the locking bolt tries to travel into the "locked" position. Since this is not possible, it travels back to the position "unlocked".

Another special case arises in connection with the emergency release. The locking bolt is pulled while the door is locked, and the door is opened. Then the locking bolt is pushed back into its original position and the door is closed again. The door will be the locked state again.

9. Assembly

1. Step

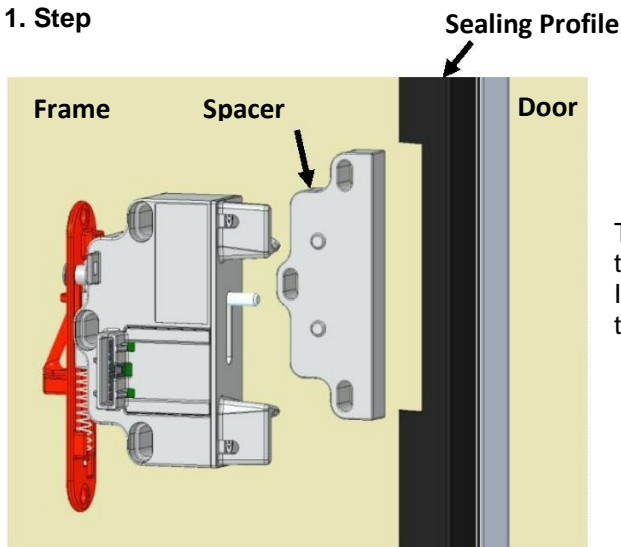

The frame unit and the spacer (optional) are mounted on the frame.
In some cases, the sealing profile lip must be cut-out for to mount frame unit / spacer.

2. Step

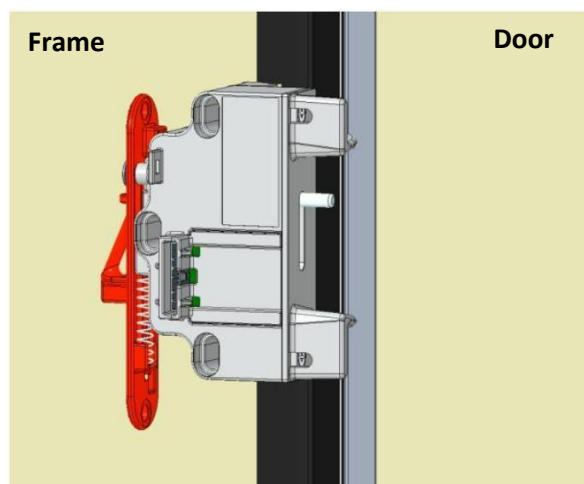

To mount the frame unit on the frame, the optimal position must be determined first.
The holes for the screws can be marked through the screw points of the frame unit.

3. Step

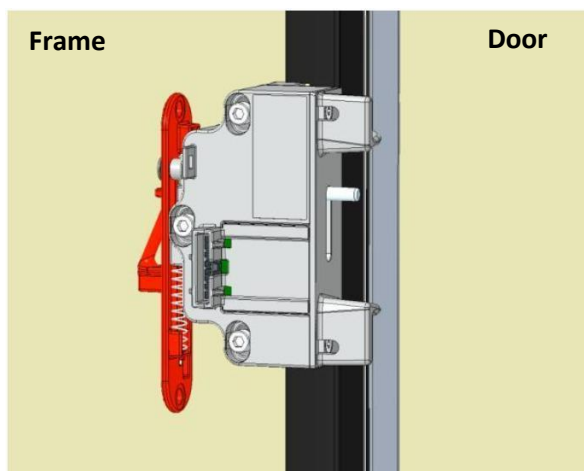

The frame unit is mounted at the screw-on points on the frame.

The screws are not included in the scope of delivery and must be selected according supporting surface.

4. Step

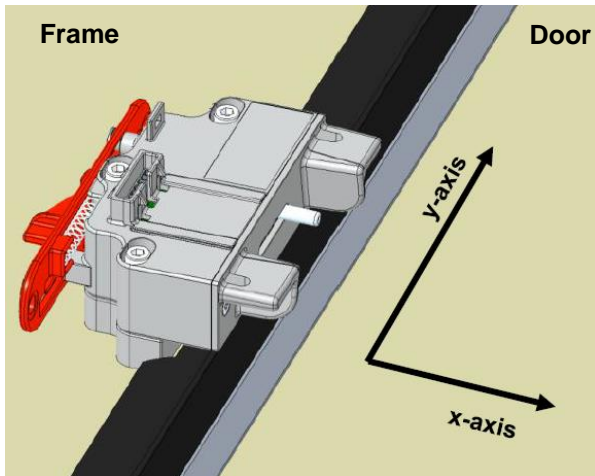

A subsequent correction of the position is only possible on the y-axis in the range $\pm 3\text{mm}$.

5. Step

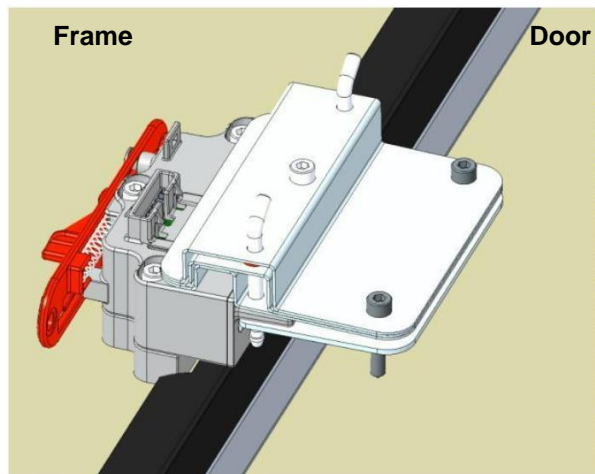

After the frame unit has been mounted, the position of the screws on the door can be marked with the assembly aid.

For this purpose, the assembly aid is attached to the frame unit and then the door is pressed on.

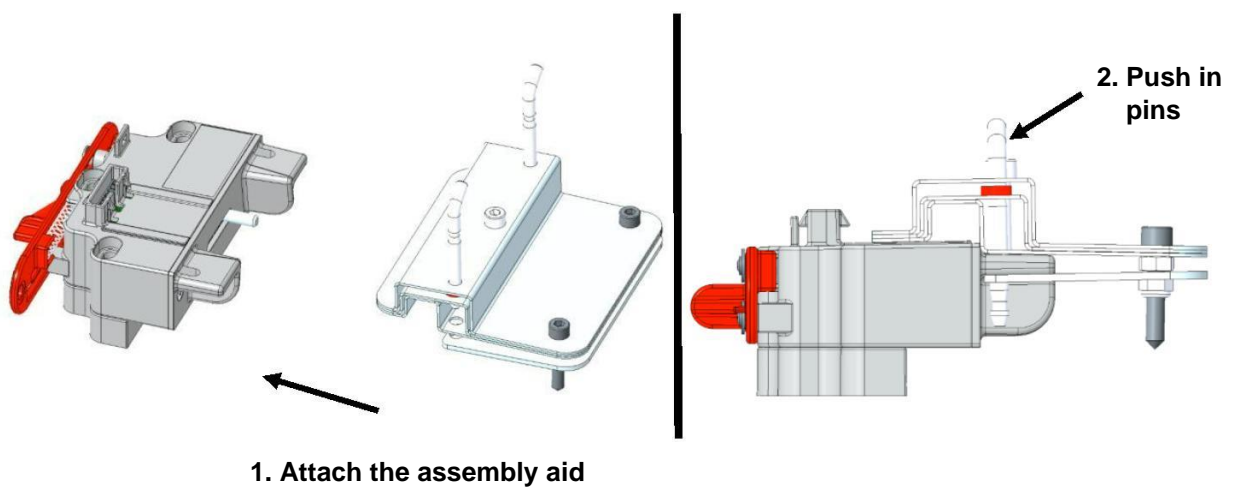

6. Step

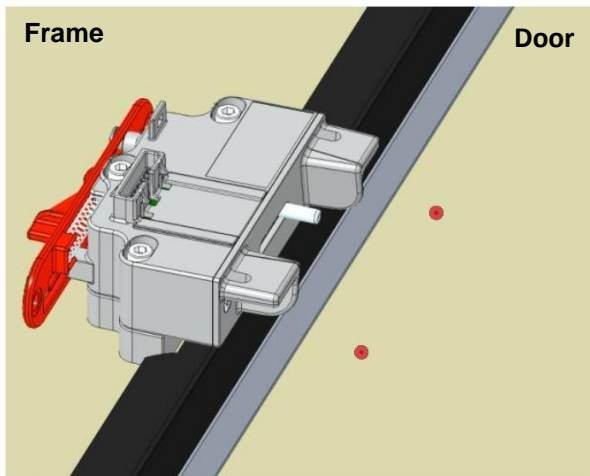

The pointed screw ends of the assembly will leave indentation points on the door.

Step 7

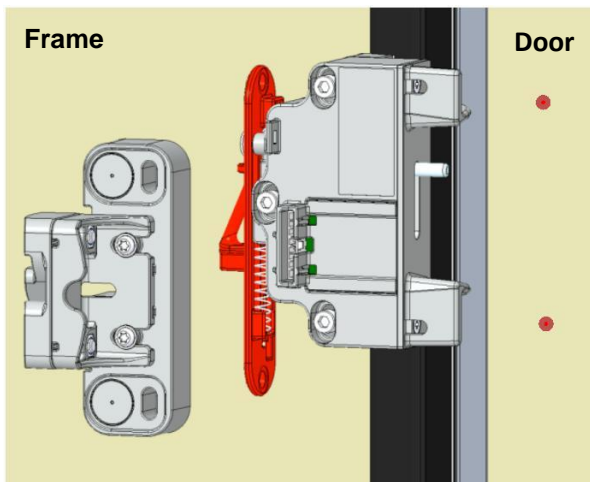

The door unit can be mounted to the indentation points on the door.

8. Step

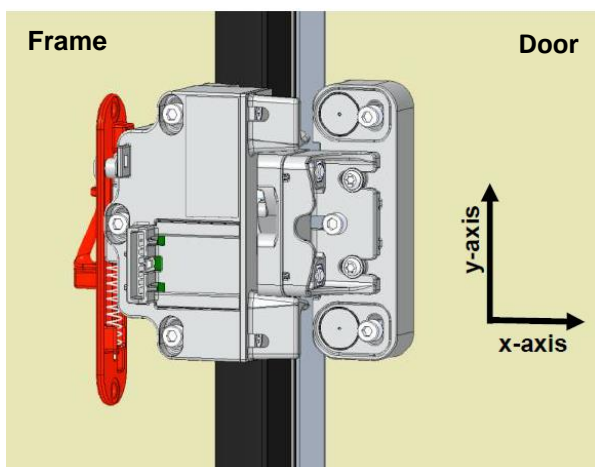

A subsequent correction of the position is possible on the x and y axes in the range ± 3 mm each.

The screws are not included in the scope of delivery and must be selected according supporting surface.

9. Step

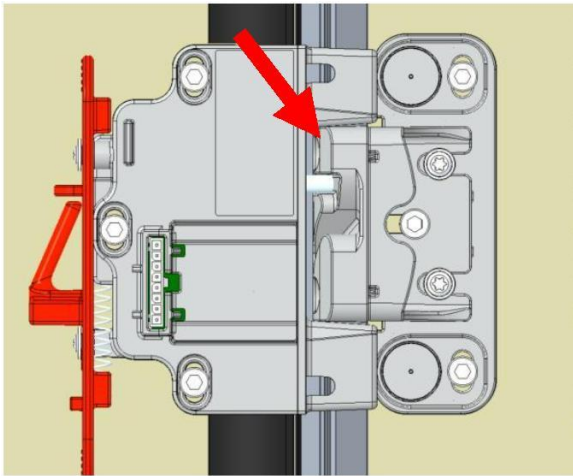

The distance between frame and door unit should be 1 ... 2 mm.

10. Step

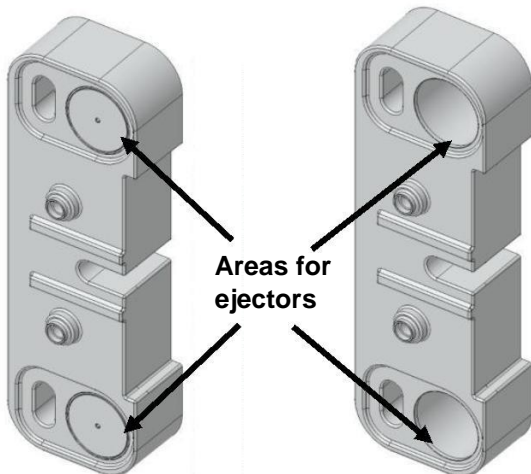

Optionally, ejectors can be used. For this purpose, the designated areas must be opened in the spacer to insert the ejectors.

11. Step

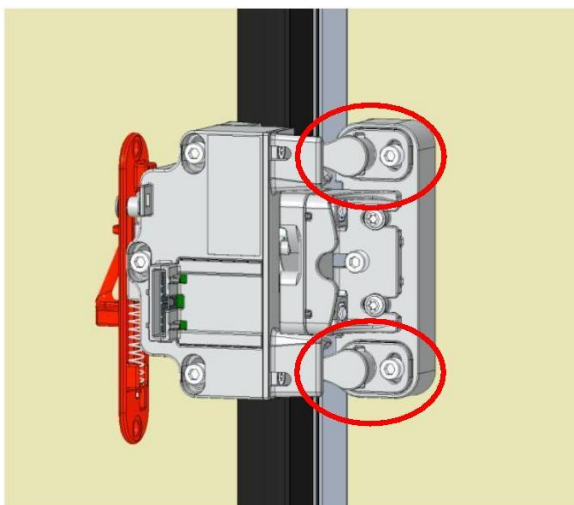

One or two ejectors can be mounted. No additional screws are required for fastening.

10. Data sheet

Life cycle test		10,000 cycles <small>(0005 / 2020)</small>	
Ambient temperature range		-20°C to +60°C <small>(0037 / 2020)</small>	
Protection		IP 20 met <small>(0158 / 2020)</small>	
Maximum static strength		F max.	530 N <small>(0157 / 2020)</small>
Tightening torque	1	M max.	1,5 Nm <small>(0156 / 2020)</small>
Tightening torque	2	M max.	1,5 Nm Cylinder screws DIN 912 – M5 were used to determine the torque. These are not included in the scope of delivery. <small>(0156 / 2020)</small>
Tightening torque	3	M max.	1,5 Nm Cylinder screws DIN 912 – M5 were used to determine the torque. These are not included in the scope of delivery. <small>(0156 / 2020)</small>
Tightening torque	4	M max.	1,5 Nm <small>(0156 / 2020)</small>

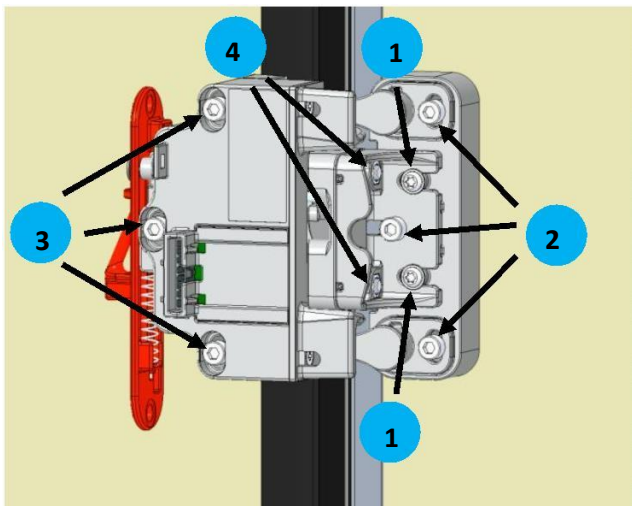

The test results obtained refer exclusively to the test object during the test period under laboratory conditions. The test results apply exclusively to the use of the product with intended use and taking into account all dependent functional features in an existing system. When using the product in a non-intended application, the determined properties are by no means transferable to the system.