

Electromechanical Lock for Cams

Type 3000-U304-04

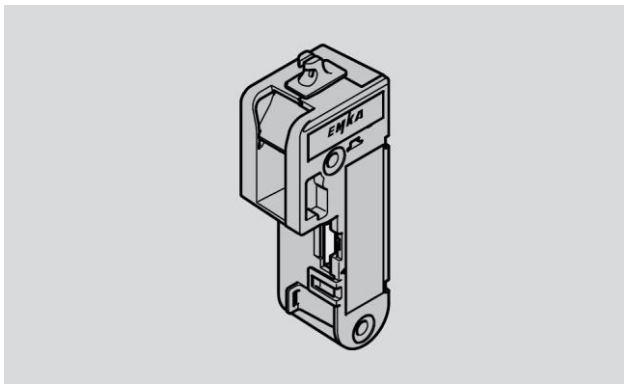

English Manual

03/2020

Table of Content

1	General information	5
2	Safety	6
2.1	Intended use	6
2.2	Operating conditions	6
2.3	Basic safety instructions.....	7
2.3.1	Avoid electric shock	7
2.3.2	Avoid injuries	7
2.3.3	Avoid damage to device.....	8
2.4	Personnel qualifications	8
2.5	Personal protective equipment.....	9
2.6	Design features of warning notices	9
2.7	Design features of references to property	10
3	Description.....	11
3.1	Overview.....	11
3.2	Application and function	12
3.3	Control	13
3.4	Application example	14
3.5	Name plate.....	15
3.6	Technical data.....	16
4	Transport and storage	17
5	Mount the device	17
5.1	Scope of delivery	17

5.2	Tools and aids required.....	17
5.3	Dimensional drawing.....	18
5.4	Mounting the device	19
5.5	Install the Bowden cable	21
6	Operate the device	22
7	Troubleshooting.....	22
8	Service the device	23
9	Dispose of the device	23

1 General information

These instructions will help you to securely install the electromechanical cam lock. In the following, the electromechanical cam lock is called “device”.

These instructions are part of the device.

- Always keep these instructions with the device.
- Include these instructions when you sell the device or pass it on in any other way.

Various elements of this manual are provided with fixed design features. So, you can easily distinguish the following elements:

normal text

- First level enumeration
- Action steps
- ❶ Tips contain additional information.

Manufacturer address

EMKA Beschlagteile GmbH & Co. KG

Langenberger Strasse 32

42551 Velbert, Germany

Phone: +49 2051/273 0

Fax: +49 2051/273 128

info@emka.de

Authorized representative for the documentation

Mr. Daniel Egener

EMKA Beschlagteile GmbH & Co. KG

Langenberger Strasse 32

42551 Velbert, Germany

Telephone: +49 202/7496 466

Fax: +49 202/7496 468

D.Egener@emka.de

2 Safety

2.1 Intended use

The electromechanical cam lock 3000-U304-04 is used to hold a cam (locking element) that is used to lock a door, flap or similar. The cam can be made of steel or another suitable material. If the cam is engaged in the catch of the device, it gives a status feedback. A door contact can be monitored.

2.2 Operating conditions

Make sure that the device is only used under the following environmental conditions:

- Temperature: -20°C to $+60^{\circ}\text{C}$
- Relative humidity: 15% to 85%, non-condensing

The device meets the requirements of protection class IP2x. Es darf nur in Einbaubedingungen verwendet werden, die der Schutzart IP54 oder besser entsprechen.

2.3 Basic safety instructions

2.3.1 Avoid electric shock

Electric shock possible when connecting the device.

- Make sure that the device is only connected by qualified electricians.
- Make sure that the conditions at the installation location correspond to the protection class of the device. The protection class can be found in the technical data.
- Before connecting, ensure that all electrical power is switched off.
- Do not put any visibly damaged device into operation.

2.3.2 Avoid injuries

Avoid injury to eyes from drilling dust possible when drilling holes.

- Wear safety glasses.

2.3.3 Avoid damage to device

Avoid damage to the electrical connection cable due to kinks.

- Lay the connection cable to the device so that it is not kinked or squeezed.

Avoid damage to the device due to excessive torque when fastening.

- Tighten screws and nuts with max. 2 Nm fixed.

Avoid damage to the device due to moisture.

- Make sure that the conditions at the installation location correspond to the protection class of the device. The protection class can be found in the technical data.

2.4 Personnel qualifications

People who assemble or connect the device must have the following skills:

- Determine visible damage to the device before installation
- Fasten screws or nuts with specified torque
- Arising danger when handling electrical devices and avoid dangers

- Establish electrical connections in accordance with applicable regulations and guidelines (electrical specialist)

2.5 Personal protective equipment

- Wear suitable personal protective equipment when working with the device.
- When compiling personal protective equipment, observe and follow the regulations at the place of use.
- Wear safety glasses when drilling holes.
- Wear hearing protection when drilling holes.

2.6 Design features of warning notices

WARNING

Warnings with the word **WARNING** warn of a dangerous situation that can lead to death or serious injuries.

ATTENTION

Notes with the word **CAUTION** warn of a situation that can lead to minor or moderate injuries.

2.7 Design features of references to property

Caution!

These warnings warn of a situation that can lead to property damage.

3 Description

3.1 Overview

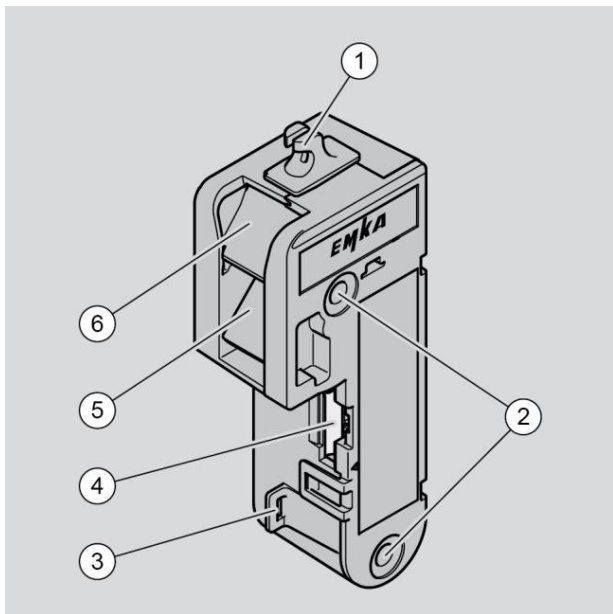

No.	Description
1	Bowden cable holder

No.	Description
2	mounting holes
3	Cable attachment for strain relief
4	connection socket, matching connector Type MATE-N-LOK (1445022-8) or EMKA connection cable art.-no. 3000-111-0
5	Feedback switch
6	Catch

3.2 Application and function

The electromechanical cam lock 3000-U304-04 is used to hold a cam (locking element) that is used to lock a door, flap or similar. The cam can be made of steel or another suitable material. Whether the cam is engaged in the latch of the device or not, the device gives a status feedback. Outputs are redundant and switching antivalent.

The cam is not included.

In addition, the cam can be prevented from opening. The cam can be released automatically by the higher-level control system or manually, for example by pressing a switch or button. This may only be done after the machine has come to a complete standstill.

The top of the device is equipped with a device for manual emergency unlocking. A suitable Bowden cable can be attached here.

3.3 Control signals and outputs

Pin assignment

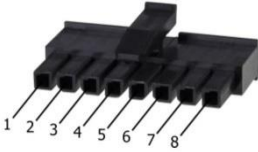
Pin	Signal	Connector
1	Open collector out	
2	-	
3	IN	
4	GND (-)	
5	VCC (+)	
6	-	
7	Door contact A1	
8	Door contact A2	

The following illustration shows the power supply and the control signal.

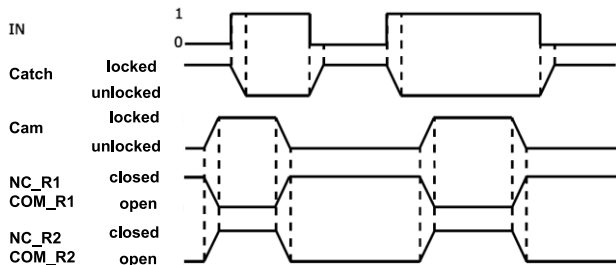

3.4 Application example

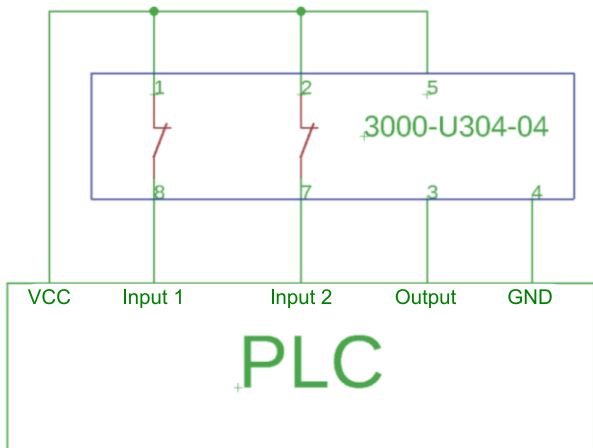

Locking and unlocking the lock

The lock is locked or unlocked via the input signal IN (Pin 3). By applying a HIGH-level signal (9... 32 VDC) the lock is unlocked. The lock is locked when a LOW-level signal (0 VDC) is applied.

Evaluation of the outputs

The position of the cam is signaled by two relay contacts (opening contacts) which are controlled ambivalent.

If the door is locked, contacts of relay 1 (NC = Pin 1, COM = Pin 8) are open, contacts of relay 2 (NC = Pin 2, COM = Pin 7) are closed.

If the door is unlocked, contacts of relay 1 (NC = Pin 1, COM = Pin 8) are closed, contacts of relay 2 (NC = Pin 2, COM = Pin 7) are open.

In the transition phases, status changes from locked to unlocked or from unlocked to locked, implausible output signals can occur. These implausible output signals, both relay contacts open or both relay contacts closed, must not last longer than 0.5 s. A closing speed of 7.5 rpm is assumed.

If these implausible output signals last longer, this must be treated as an error.

3.5 Name plate

The type label is on the housing of the device. It contains the following information:

- Product name
- Item number
- Serial number
- Date of manufacture (week, year, month)
- Input voltage range
- maximum power consumption
- QR code

- Icon of the WEEE directive (garbage bin)
- CE mark
- Manufacturer logo
- Internet address
- Country of origin

3.6 Technical data

Dimensions and weight

Dimensions approx. (W x H x D)	42 x 117.1 x 30.5 mm
Weight about	80 g

Electrical characteristics

Supply voltage VCC	9-32 VDC (SELV)
Current consumption	max. 120 mA; standby 9 mA
Transistor output	Max. 30 V, 50 mA
Protection class	IP2x

4 Transport and storage

To transport and store the device, proceed as follows:

- Transport and store the device in the original packaging.
- Store the device in a dry room.

5 Mount the device

5.1 Scope of delivery

The device, including instructions, is supplied packed in a box.

5.2 Tools and aids required

You will need the following to mount the device:

- Open-end wrench WAF8
- Torque wrench with WAF8 insert
- Drilling machine

- Drill with diameter 5.2 mm
- Calliper
- Countersink

5.3 Dimensional drawing

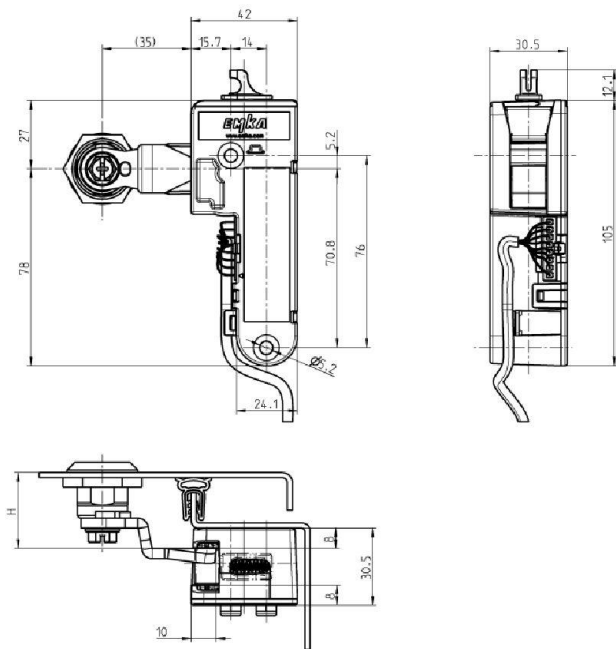

5.4 Mounting the device

WARNING

Electric shock possible due to improper connection of the device.

- Make sure that the device is only connected by qualified electricians.
- Before connecting, ensure that power is switched off.

ATTENTION

Injury to eyes from drilling dust possible when drilling holes.

- Wear safety glasses.

Caution!

Damage to the device due to excessive torque when fastening.

- Tighten screws and nuts with max. 2 Nm.

You can use stud bolts or screws to mount the device. To assemble the device, proceed as follows:

- Mark the position of the mounting holes according to the dimensional drawing (only when using screws).
- Drill the mounting holes (only when using screws).
- Fasten the device (6) with two stud bolts / screws (5), washers (3) and nuts (4).
- Tighten the screws / nuts with a torque of max. 2 Nm.
- Mount the cam (9) not included in the scope of delivery in the door / flap (1) as described in the associated instructions.
- Make sure that the inside dimension is correct.
- Connect the device to the higher level using the connector (8) not included in the scope of delivery. Suitable connectors see description.
- Check the assignment of the electrical connections from the technical data.
- Secure the cable with a cable tie to the cable fastening (7).
- Check that the device is working properly.

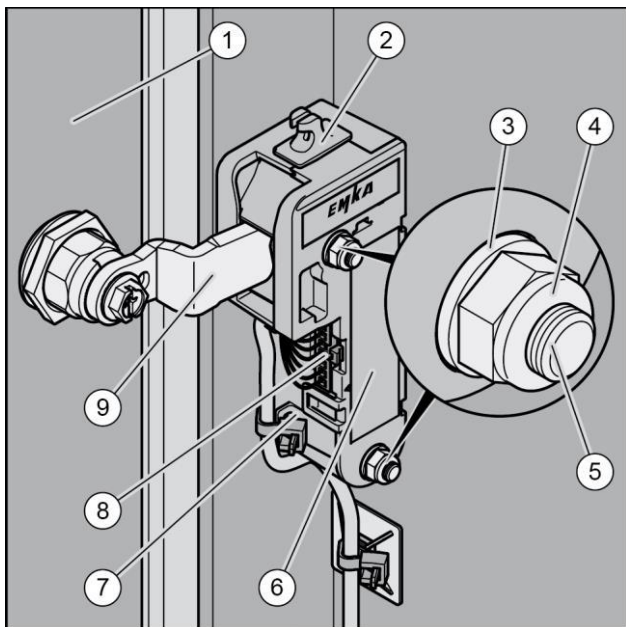

5.5 Install the Bowden cable

The device is equipped with an emergency release, which can be used to unlock it in the event of a power failure.

- Hang the Bowden cable in the dedicated Bowden cable holder (2) on the device, see previous illustration.
- Connect the Bowden cable to the designated unlocking device.
- Check the function.

6 Operate the device

The device is operated (unlocked, locked) via the connected higher-level control system, alternatively via a button / switch.

- For further information check the instructions for the control system.

7 Troubleshooting

Feature	Cause	Measure
Function not plausible	Broken cable function	Replace defective plausible cable against a flawless one.
No function	Function plug not correctly inserted	Insert the plug up to stop on.

Feature	Cause	Measure
No function	Device with excessive torque attached	Unscrew the device. Fasten again with torque of max. 2 Nm.
Device cannot be locked	Emergency release was actuated.	Release the emergency release.

8 Service the device

- Carry out a manual function test every 12 months.

9 Dispose of the device



Dispose of the device through an authorized waste disposal company. Observe and follow the applicable rules and regulations. If in doubt, contact your municipality or city administration.