

## Single Point Latch

Type 3000-U301-03

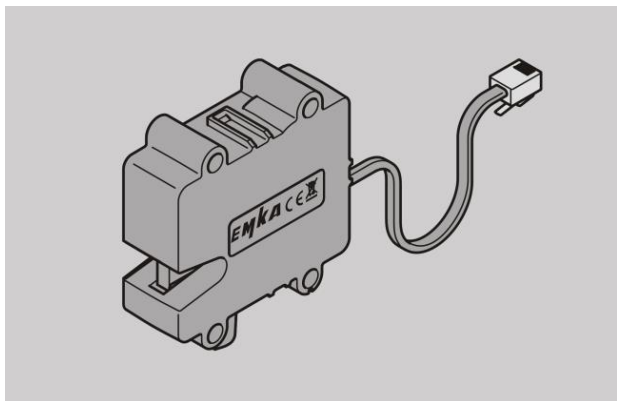

English Manual

03/2021



## Table of Content

1	General information .....	5
2	Safety .....	6
2.1	Intended use .....	6
2.2	Operating conditions .....	6
2.3	Basic safety instructions.....	7
2.3.1	Avoid electric shock .....	7
2.3.2	Avoid injuries .....	7
2.3.3	Avoid damage to device.....	7
2.4	Personnel qualifications .....	8
2.5	Personal protective equipment.....	8
2.6	Design features of warning notices .....	9
2.7	Design features of references to property .....	9
3	Description.....	10
3.1	Overview.....	10
3.2	Application and function .....	11
3.3	Control signals .....	12
3.4	Application example .....	13
3.5	Name plate.....	15
3.6	Technical data.....	16
4	Transport and storage .....	16
5	Mount the device .....	17

5.1	Scope of delivery .....	17
5.2	Tools and aids required.....	17
5.3	Dimensional drawing.....	18
5.3.1	Catch and locking bolt.....	18
5.3.2	Adaptor plate .....	19
5.4	Mounting the device .....	20
5.4.1	Mounting the device with catch .....	21
5.4.2	Mounting the device with locking bolt.....	23
5.4.3	Mounting the device with adaptor plate .....	25
5.5	Install emergency release .....	26
6	Operate the device .....	27
7	Troubleshooting.....	28
8	Service the device .....	29
9	Dispose of the device .....	29

## 1 General information

These instructions will help you to securely install the Single Point Latch. In the following, the Single Point Latch is called “device”.

These instructions are part of the device.

- ▶ Always keep these instructions with the device.
- ▶ Include these instructions when you sell the device or pass it on in any other way.

Various elements of this manual are provided with fixed design features. So, you can easily distinguish the following elements:

normal text

- First level enumeration
- ▶ Action steps
- ❗ Tips contain additional information.

### **Manufacturer address**

EMKA Beschlagteile GmbH & Co. KG

Langenberger Strasse 32

42551 Velbert, Germany

Phone: +49 2051/273 0

Fax: +49 2051/273 128

info@emka.de

Authorized representative for the documentation  
Mr. Sebastian Geck  
EMKA Beschlagteile GmbH & Co. KG  
Langenberger Strasse 32  
42551 Velbert, Germany  
Phone: +49 202/7496 462  
Fax: +49 202/7496 468

## **2 Safety**

### **2.1 Intended use**

The Single Point Latch 3000-U301-03 is used to hold a locking element (catch or bolt) that is used to lock a door, flap or similar. The locking element can be made of steel or another suitable material.

### **2.2 Operating conditions**

Make sure that the device is only used under the following environmental conditions:

- Temperature: -20 ° C to +60 ° C
- Relative humidity: 15% to 85%, non-condensing

The device meets the requirements of protection class IP2x.

## **2.3 Basic safety instructions**

### **2.3.1 Avoid electric shock**

Electrical shock possible when connecting the device.

- ▶ Make sure that the device is only connected by qualified electricians.
- ▶ Make sure that the conditions at the installation location correspond to the protection class of the device. The protection class can be found in the technical data.
- ▶ Before connecting, ensure that all electrical power is switched off.
- ▶ Do not put any visibly damaged device into operation.

### **2.3.2 Avoid injuries**

Avoid injury to eyes from drilling dust when drilling holes.

- ▶ Wear safety glasses.

### **2.3.3 Avoid damage to device**

Avoid damage to the electrical connection cable due to kinks.

- ▶ Lay the connection cable to the device so that it is not kinked or squeezed.

Avoid damage to the device due to excessive torque when fastening.

- ▶ Tighten screws and nuts with max. 2 Nm

Avoid damage to the device due to moisture.

- ▶ Make sure that the conditions at the installation location correspond to the protection class of the device. The protection class can be found in the technical data.

## **2.4 Personnel qualifications**

People who assemble or connect the device must have the following skills:

- Determine visible damage of the device before installation
- Fasten screws or nuts with specified torque
- Identify hazards that may occur when handling electrical equipment and avoid hazards
- Establish electrical connections in accordance with applicable regulations and guidelines (electrical specialist)

## **2.5 Personal protective equipment**

- ▶ Wear suitable personal protective equipment when working with the device.

- ▶ When compiling personal protective equipment, observe and follow the regulations at the place of use.
- ▶ Wear safety glasses when drilling holes.
- ▶ Wear hearing protection when drilling holes.

## 2.6 Design features of warning notices

### **WARNING**

Warnings with the word **WARNING** warn of a dangerous situation that can lead to death or serious injuries.

### **ATTENTION**

Notes with the word **ATTENTION** warn of a situation that can lead to minor or moderate injuries.

## 2.7 Design features of references to property

### **Caution!**

These warnings warn of a situation that can lead to property damage.

## 3 Description

### 3.1 Overview

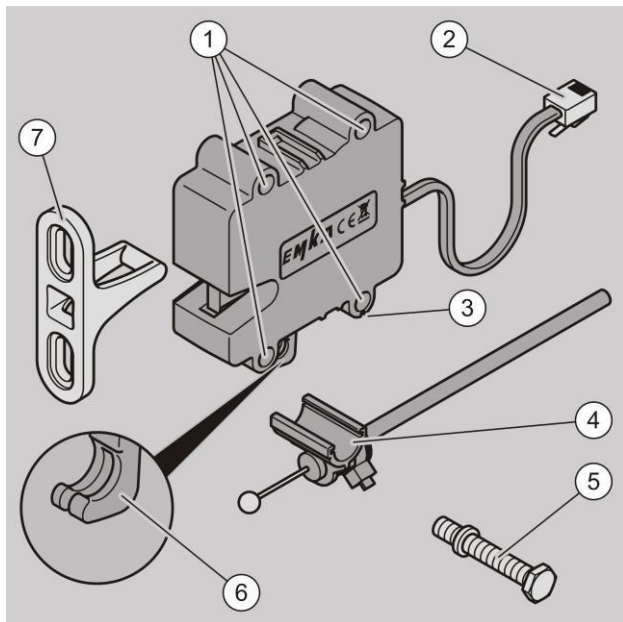

No.	Description
1	Mounting holes

No.	Description
2	Electrical connector
3	Bowden cable support
4	Bowden cable holder
5	Locking bolt
6	Lever for mechanical unlock and Bowden cable insert
7	Catch

### 3.2 Application and function

The Single Point Latch 3000-U301-03 is used to hold a locking element (catch or bolt) that is used to lock a door, flap or similar. The locking element can be made of steel or another suitable material.

The catch is included. The locking bolt (art.-no. 3000-102-JB) is available as an accessory.

To unlock the device, supply voltage must be switched off. Locking is by manually closing the door. For proper unlock, the device must have been connected to the supply voltage for minimum 60 seconds.

The device is equipped with a lever for manual emergency unlocking on the bottom side. A suitable Bowden cable can be attached here.

### 3.3 Control signals

#### Pin assignment

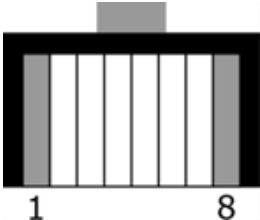
Pin	Signal	Wire color	Connector
1	-	-	
2	-	-	
3	Contact	black	
4	V (-)	red	
5	V (+)	Green	
6	Contact	yellow	
7	-	-	
8	-	-	

The following illustration shows how to control the device. Power supply is used as control signal for this version.

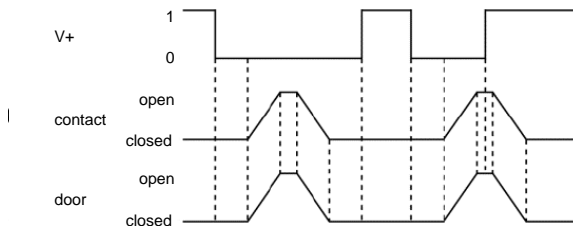

### 3.4 Application example

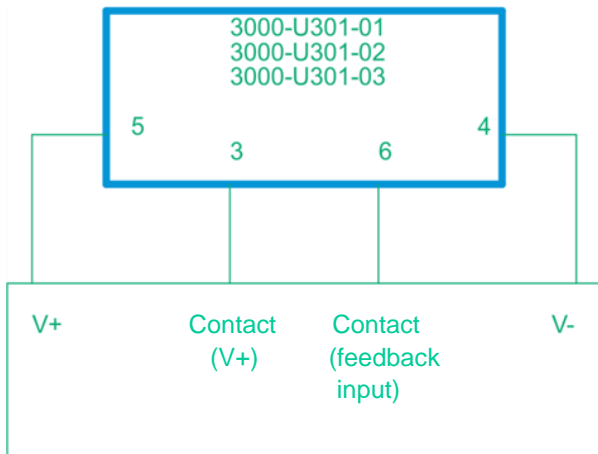

The above example shows how to monitor the status of a single point latch in a PLC system. Switching off power supply (V+) will open the latch and switch off the feedback signal on the PLC input to indicate status “open”.

#### Locking and unlocking

The device must be connected to permanent supply voltage via the connectors V+ and V-. To unlock the device, supply voltage must be switched off.

Locking is by manually closing the door. For proper unlock, the device must have been connected to the supply voltage for minimum 60 seconds.

### 3.5 Name plate

The type label is on the housing of the device. It contains the following information:

- Product name
- Item number
- Serial number
- Input voltage range
- maximum power consumption
- Exclamation mark (consult manual)

## 3.6 Technical data

### Dimensions and weight

Dimensions approx. (W x H x D)	72 x 84.46 x 24 mm (w/o Bowden cable holder) 72 x 86.65 x 24 mm (with Bowden cable holder)
Weight device	115 g
Weight locking bolt	12 g
Weight catch (AISI 316)	56 g
Weight catch (GD-Zn)	44 g

### Electrical characteristics

Supply voltage VCC	9–32 VDC (SELV)
Current consumption	max. 100 mA
Contact rating	max. 30 VDC min. 1 mA, max. 100 mA
Protection class	IP2x

## 4 Transport and storage

To transport and store the device, proceed as follows:

- ▶ Transport and store the device in the original packaging.
- ▶ Store the device in a dry room.

## **5 Mount the device**

### **5.1 Scope of delivery**

- Device
- Catch GD-Zn
- Data sheet
- Packed in a box

### **5.2 Tools and aids required**

You will need the following to mount the device:

- Open-end wrench WAF8
- Torque wrench with WAF8 insert
- Drilling machine
- Drill with diameter 5.2 mm
- Calliper
- Countersink

## 5.3 Dimensional drawing

### 5.3.1 Catch and locking bolt

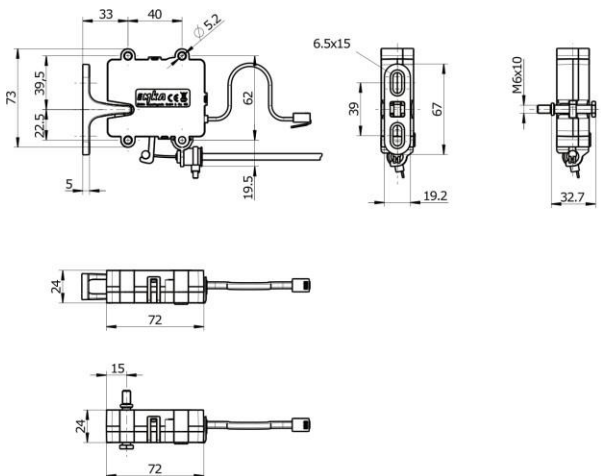

### 5.3.2 Adaptor plate

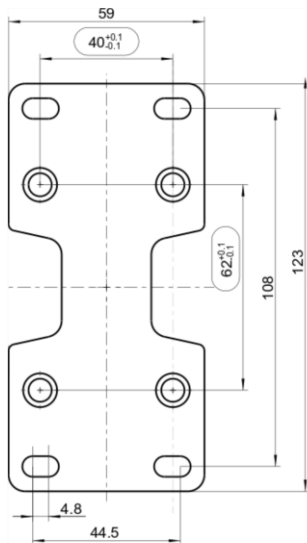

## 5.4 Mounting the device

### **WARNING**

**Electric shock possible due to improper connection of the device.**

- ▶ Make sure that the device is only connected by qualified electricians.
- ▶ Before connecting, ensure that power is switched off.

### **ATTENTION**

Injury to eyes from drilling dust possible when drilling holes.

- ▶ Wear safety glasses.

### **Caution!**

Damage to the device due to excessive torque when fastening.

- ▶ Tighten screws and nuts with max. 2 Nm.

### 5.4.1 Mounting the device with catch

To mount the device, proceed as follows:

- ▶ Mark the position of the mounting holes according to the dimensional drawing; ref. to page 17.
- ▶ Drill the mounting holes.
- ▶ Fasten the device to the frame or housing (not shown).
- ▶ Tighten the screws / nuts with a torque of max. 2 Nm.

To mount the catch to a door / flap, proceed as below:

- ▶ Mark the position of the mounting holes according to the dimensional drawing; ref. to page 17.
- ▶ Drill the mounting holes.
- ▶ Fasten catch (1) with two screws.
- ▶ Tighten the screws / nuts with a torque of max. 2 Nm.
- ▶ Plug the connector (2) into the control device.

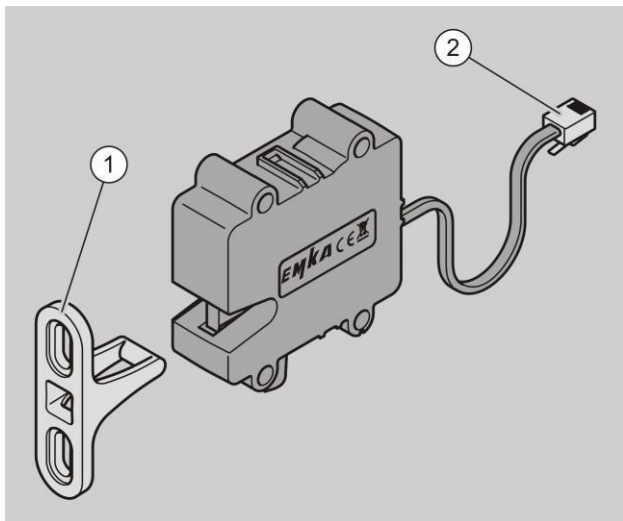

- ▶ Check the assignment of the electrical connections from the technical data.
- ▶ Check that the device is working properly.

Optionally, the device and the catch can be fastened with thread bolts. To do this, proceed as follows:

- ▶ Position the thread bolts using the corresponding dimensions from the dimensional sketch; ref. to see page 17.
- ▶ Place the device and the lock holder on the thread bolts (not shown).
- ▶ Screw the nuts onto the thread bolts. Tighten the nuts to a torque of max. 2 Nm.
- ▶ Connect the plug of the device to the control unit.
- ▶ Check the assignment of the electrical connections from the technical data.
- ▶ Check the proper functioning of the device.

#### **5.4.2 Mounting the device with locking bolt**

To mount the device, proceed as follows:

- ▶ Mark the position of the mounting holes according to the dimensional drawing to page 17.
- ▶ Drill the mounting holes
- ▶ Fasten the device to the frame or housing

- ▶ Tighten the screws / nuts with a torque of max. 2 Nm.

To mount the locking bolt to a door / flap, proceed as below:

- ▶ Mark the position of the mounting hole according to the dimensional drawing; ref. to page 17
- ▶ Drill the mounting hole
- ▶ Insert locking bolt (3) in hole (1).
- ▶ Mount the locking bolt with a nut. Tighten the nut with a torque of max. 2 Nm.
- ▶ Alternatively, screw the locking bolt (3) into a premanufactured thread hole (M6, not shown)
- ▶ Plug the connector (2) into the control device.

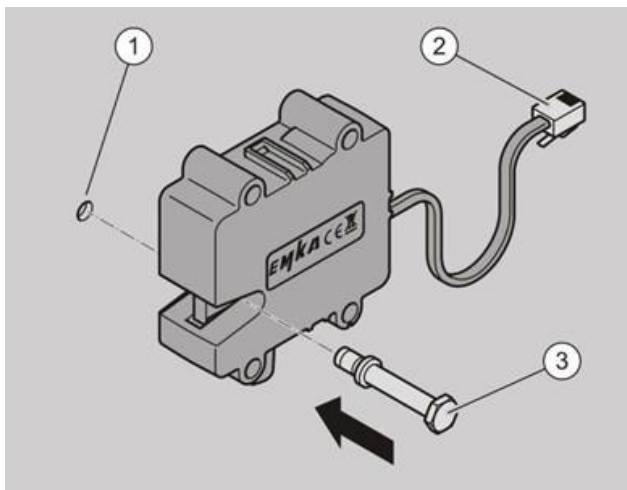

- ▶ Check the assignment of the electrical connections from the technical data.
- ▶ Check the proper functioning of the device.

### 5.4.3 Mounting the device with adaptor plate

Optionally, the device can be attached to the frame or housing using an adaptor plate (art.-no.: 3000-U302-00). The adaptor plate is used to mount the device to a different hole pattern. To mount the device with an adaptor plate, proceed as follows:

- ▶ Mark the position of the mounting holes according to the dimensional drawing (ref. to page 18).
- ▶ Drill the mounting holes
- ▶ Mount the device to the adaptor plate (not shown)
- ▶ Fasten the device with screws. Tighten the screws with a torque of max. 2 Nm.
- ▶ Mount the device to the adaptor plate to the frame or housing (not shown)
- ▶ Fasten the adaptor plate with screws. Tighten the screws with a torque of max. 2 Nm.

## **5.5 Install emergency release**

The device is equipped with an emergency release lever which can be used to unlock it in the event of a power failure. To install the emergency release, proceed as follows:

- ▶ Slide the Bowden cable holder onto the Bowden cable insert (1) of the device.
- ▶ Connect the Bowden cable to the designated unlock lever (2) on the device.
- ▶ Check the function.

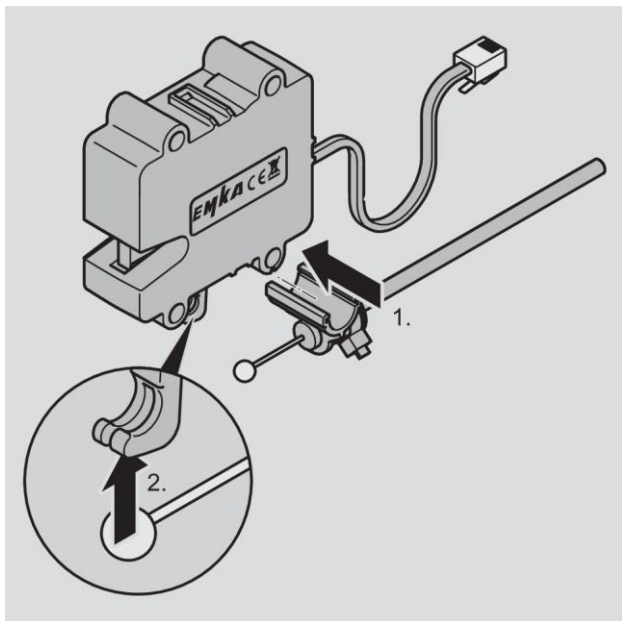

## 6 Operate the device

To unlock the catch, proceed as follows:

- ▶ Connect the device to the power supply via the terminals V+ and V- for minimum 60 seconds.

- ▶ Disconnect power supply The unlocking process starts.
- ▶ The catch is ejected.
- ▶ The potential-free switch opens

The door is locked as soon as it is closed again. To open the device again, switch on the supply voltage for minimum 60 seconds and switch off again.

## 7 Troubleshooting

Feature	Cause	Measure
Status "locked" not indicated	Broken cable	Replace defective cable against a flawless one.
No function	Device not connected	Make sure device is properly connected
	Device screwed tight with too high torque	Unscrew and tighten screws again with correct torque
Device does not lock	Emergency unlock lever pulled	Release unlock lever
	Supply voltage applied too short	Switch on power supply for min. 5 seconds

Feature	Cause	Measure
Device cannot be unlocked	Supply voltage applied too short	Switch on power supply for min. 60 seconds
	Pre-load too high	Ensure that pre-load does not exceed the device limits
	Broken cable	Replace cable

## 8 Service the device

- ▶ Carry out a manual function test every 12 months.

## 9 Dispose of the device



Dispose of the device through an authorized waste disposal company. Observe and follow the applicable rules and regulations. If in doubt, contact your municipality or city administration.