



AGENT E Wireless – Schwenkgriff mit integriertem RFID Kartenleser und Funkanbindung

Die Schwenkgriffe der Baureihe AGENT E Wireless verfügen über einen integrierten Kartenleser für RFID Karten. Die Griffe kommunizieren drahtlos über Funk mit Access Units 3000-U98x-02, die mit einer zentralen Control Unit 3000-U14x-02 verbunden sind. Über diesen Weg erfolgen die Konfiguration der Griffe, Weiterleitung der Informationen zur gelesenen Karte, Öffnungszustand und Batteriestatus. Nachdem eine Karte vom System als berechtigt identifiziert wurde, öffnet der Griff. Eine Fernöffnung über Netzwerk ist ebenfalls möglich. Bis zu 5 Master RFID Karten können im Griff gespeichert werden, um eine Öffnung auch bei Ausfall des Funknetzes zu gewährleisten.

Technische Änderungen vorbehalten. Weiterführende Informationen unter www.emka-electronics.com.



AGENT E Wireless – Swing Handle with RFID Card Reader and Radio Connection

Swing Handles series AGENT E Wireless have a built-in card reader for RFID cards. Handles communicate wireless via radio connection to Access Units 3000-U98x-02, which are connected to a central Control Unit 3000-U14x-02. Transmission of handle configuration, card information, handle status (open/closed) and battery status is via this way. After presenting an authorized card, the handle will open. Remote opening via network is also possible.

Up to 5 RFID Master Cards can be entered to enable opening in case radio connection is not available.

Subject to technical changes. Further information can be found under www.emka-electronics.com.



Power supply: 2 x AAA battery
 RFID cards: 125 kHz Prox (3000-U90x-3x)
 13.56 MHz (3000-U90x-4x)
 Radio Frequency: 868 MHz (Europe)
 922 MHz (USA, Singapore)

Note

- Install batteries first before closing the handle
- Install and screw tight battery cover before operating the handle. Without cover, batteries may fall off.

Open handle Procedure

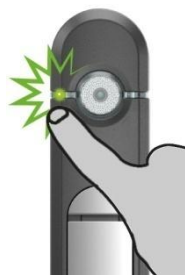

Fig. 2: Touch outer surface until left LED starts blinking.

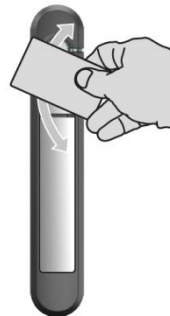

Fig. 3: Immediately swipe RFID card over reader area



Fig. 4: With valid RFID card, right LED starts blinking and handle opens. Red LED indicates invalid card

Replacing batteries



Fig. 6: Open handle and remove battery cover first to change batteries

Emergency power supply



Fig. 7: Remove USB cover, connect to laptop or mobile phone charger for powering up in case of battery failure

Dimensions

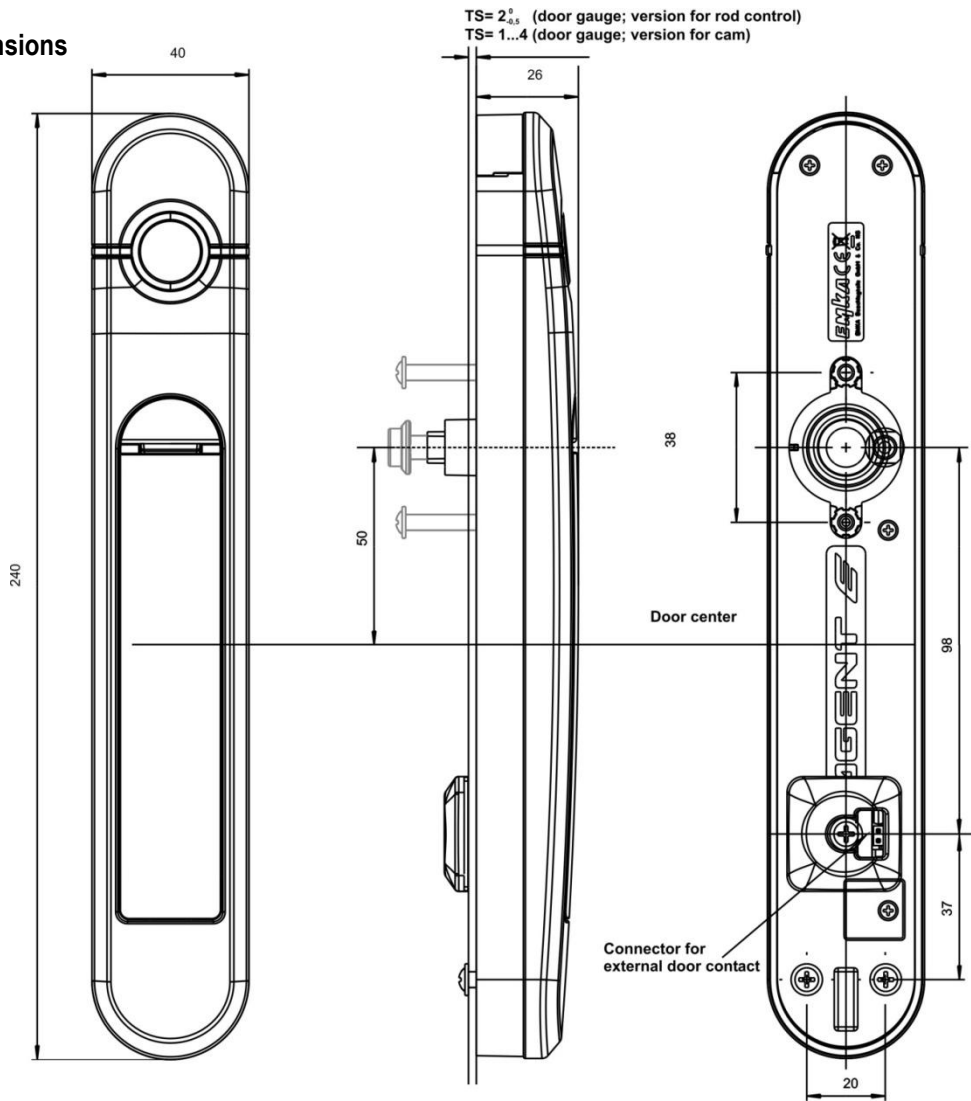

Suitable door cutouts

